

# iTP-60

*New concept for high-speed drawing operation*

Balanced cam curve

High rigidity with semi-straight side frame

Servo cross motion device helps high-speed production

Direct acting vertical transfer

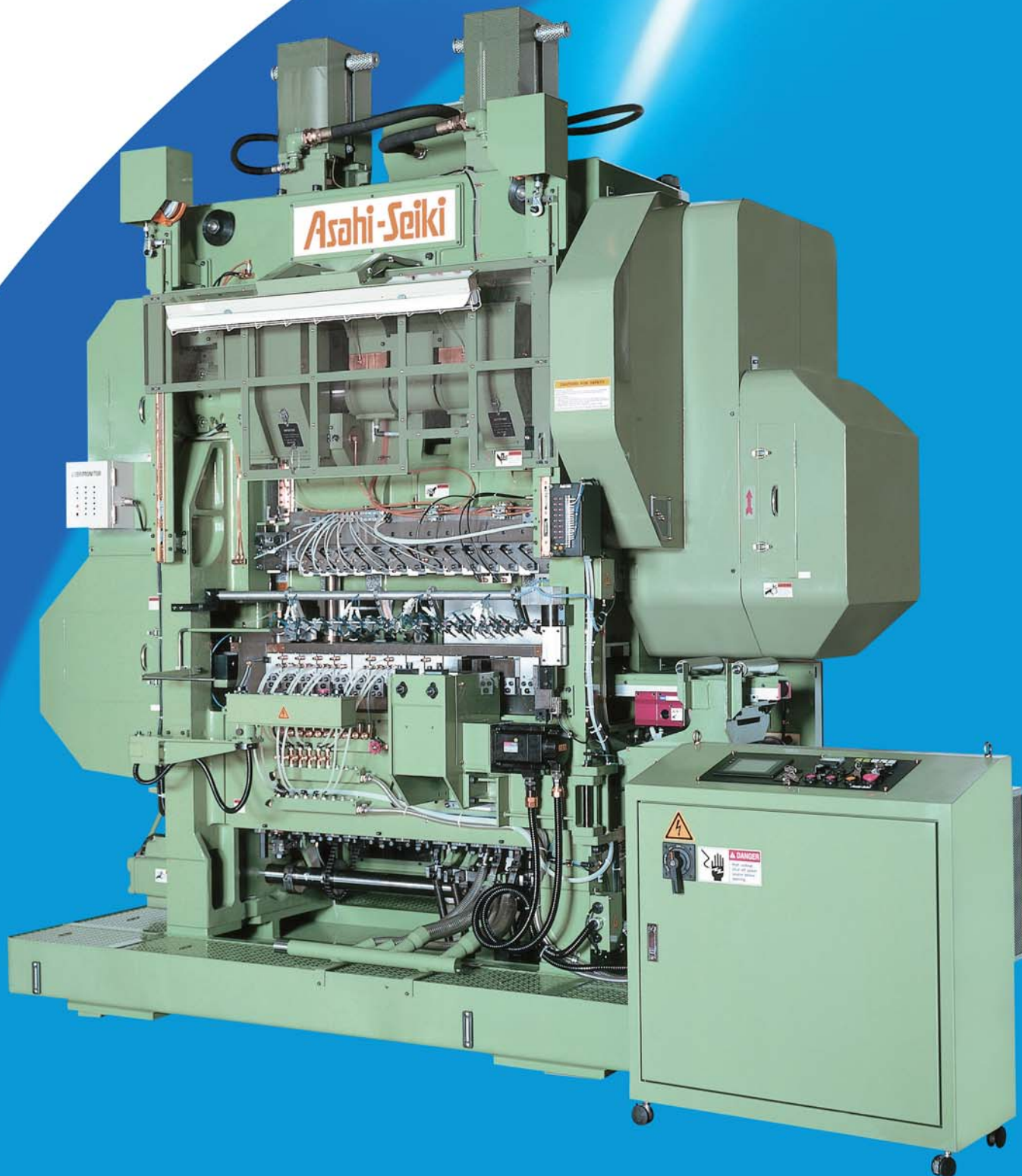

### Servo cross motion device



### Basic machine specification

Rated capacity (kN)		600
Recommended capacity (kN)		420
Ram stroke (mm)		180
Lower dwell angle of ram (deg)		20
Shut height (mm)		510
Electric power source (V)		200
Main motor		15kW, 4P
Strokes per minute (min <sup>-1</sup> )		40~150 stepless
Machine size	Height (mm)	3650
	Width (mm)	3230
	Depth (mm)	1710
Machine weight (ton)		17

### Example - Die set specification

Max. draw (mm)		77
Max. width of material (mm)		168
Max. feed length of material (mm)		102
Number of stations	14	16
Center distance between stations (mm)	90	77
Max. blank diameter (mm)		φ88

### Standard accessories

- 1) Inverter motor
- 2) Air clutch brake
- 3) Lower knockout mechanism
- 4) Back roll feed mechanism
- 5) Transfer device
- 6) Upper plunger device
- 7) Automatic lubrication device
- 8) Air valve device
- 9) Box type base (Oil pan)
- 10) Machine lamp
- 11) Execution for machine oil circulation
- 12) Camless sequence control (PLC)
- 13) Outlet for 100V & 200V

### Direct acting vertical transfer for blanking & cupping at #1 station

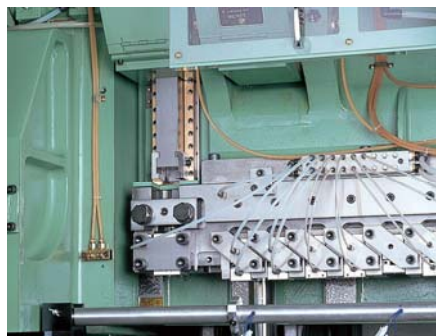

### Example - Products

#### Aluminum prismatic battery case

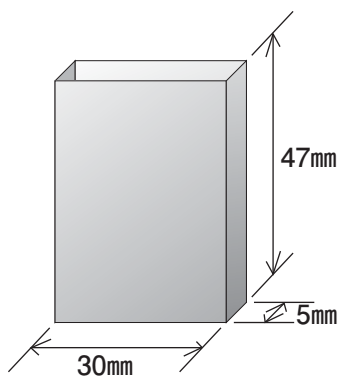

Output: 100 pcs/min.

#### Steel cylindrical battery case

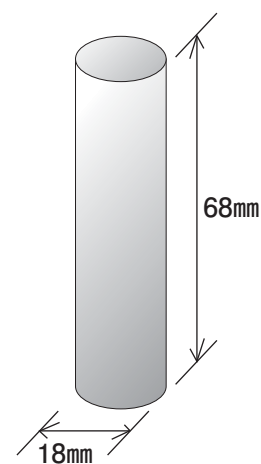

Output: 100 pcs/min.

### Special accessories

- 1) Punch stripper & stop relief device
- 2) Zig-Zag feeding device
- 3) CNC Zig-Zag feeding device
- 4) Oil lubrication device (Pump type)
- 5) Oil lubrication device (Charge tank type)
- 6) Workpiece transfer detecting device
- 7) Safety cover
- 8) Additional air valve
- 9) Vibration proof mount
- 10) Releasing device
- 11) Punch & Die cooling device
- 12) Servo cross motion device
- 13) Knockout driving device
- 14) Vacuum device
- 15) Passport
- 16) Punch breakage detecting device
- 17) Touch out sensor
- 18) Miniature conveyor
- 19) Lubrication oil discharge check sensor



## Asahi-Seiki Manufacturing Co., Ltd.

#### Head Office

Asahimae-cho, Owariasahi, Aichi, 488-8655 Japan  
 TEL 0561-53-3119 FAX 0561-54-2439  
 Home page: <http://www.asahiseiki-mfg.co.jp>

#### Tokyo branch

1-6-3 Yushima, Bunkyo-ku, Tokyo, 113-0034 Japan  
 TEL 03-5805-6991 FAX 03-5805-6992

#### Osaka sales Office

1-13-41 Esaka-cho, Suita, Osaka, 564-0063 Japan  
 TEL 06-6368-6251 FAX 06-6368-6252