

TRANSFER PRESS

Asahi-Seiki Manufacturing Co., Ltd.

LTP-45

Ultimate solution for mass production of cylindrical lithium ion battery (18650) cell !

锂离子电池(18650)用
圆形钢壳规模量产的王牌!



※这图片的主机罩子是可选的。
※Machine cover shown in this picture is an option.

1. 高速生产 High-speed production

采用直线导轨零间隙

Zero clearance with linear guides

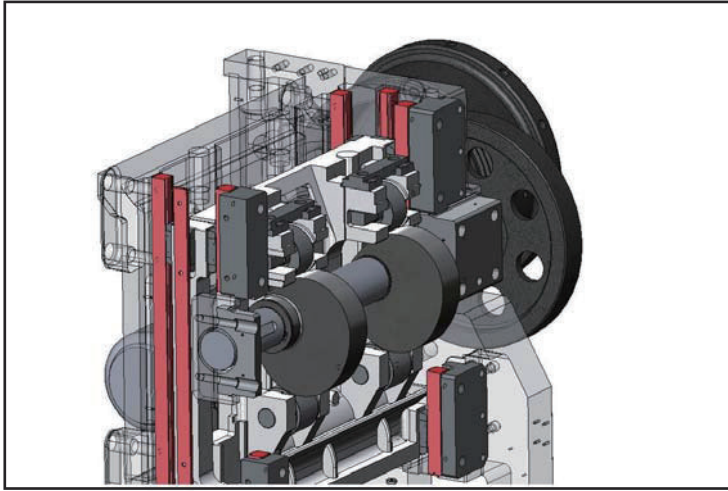

提高设备精度、实现稳定高速运转

Increased machine accuracy enables consistent high-speed production.

轻量滑块

Light ram

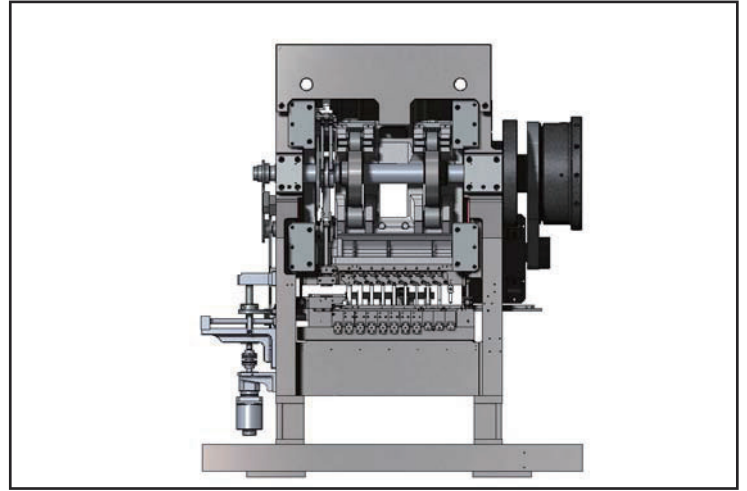

滑块的轻量化、实现高速运转

Reduced weight of ram realizes high-speed production.

2. 性价比 Cost-saving

大幅度变革侧轴部分的机构

Significantly improved side mechanism

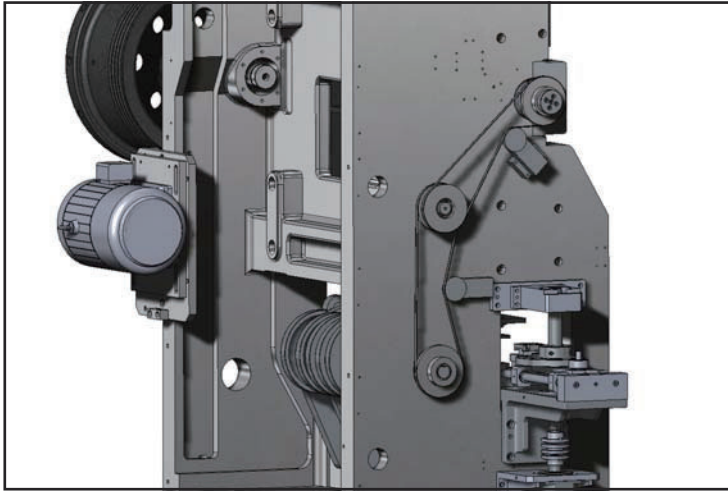

减少油脂加油点、消减油脂使用量

Reducing consumption in grease by decreasing parts to be greased

传递结构上采用伺服电机、消减润滑油使用量

Reducing consumption in lubrication oil by adopting servomotor for transfer mechanism

规格 Specifications

额定能力/Rated capacity	450 kN	
推荐能力/Recommended working load	315 kN	
滑块行程/Ram stroke	180 mm	
滑块停留角度/Ram lower dwell	20°	
闭合高度/Shut height	470 mm	
材料最大宽度/Max. width of material	150 mm	
最大送料长度/Max. feeding length	45 mm (170 min ⁻¹)	
主电机/Main motor	15kW, 4P	
机械速度/Strokes per minute	60 ~ 170 min ⁻¹	
机械尺寸 External dimension	高度/Height	3,380 mm
	宽度/width	2,870 mm
	厚度/Depth	1,780 mm
机械重量/Machine weight	13.0 ton	
第一工位加压能力/#1st.capacity	20 kN	
工位间隔 X 工位数(最大)/center distance between stations x number of stations(Max.)	77mmx 12工位	
最大拉伸高度/Max. draw	72.0 mm	



旭精機工業株式会社

本社 〒488-8655 愛知県尾張旭市旭前町新田洞5050-1
TEL 0561-53-3119 (販売部ダイヤルイン) FAX 0561-54-2439
ホームページ <http://www.asahiseiki-mfg.co.jp>

東京支店 〒113-0034 東京都文京区湯島1-6-3
TEL 03-5805-6991(代) FAX 03-5805-6992

大阪営業所 〒564-0063 大阪府吹田市江坂町1-13-41
TEL 06-6368-6251(代) FAX 06-6368-6252

代理店